

## 加速器用パルスパワー電源の特性評価と改善

### EVALUATION AND IMPROVEMENT OF PULSE POWER SUPPLY FOR ACCELERATOR

巩政<sup>#</sup>, 須貝太一, 徳地明, 江偉華

Zheng Gong, Taichi Sugai, Akira Tokuchi, Weihua Jiang

Nagaoka University of Technology

#### Abstract

In the International Linear Collider (ILC) project, 10 MW Multi-Beam klystron are used as power supply. Multi-Beam klystron specifications are -120 kV ( $\pm 0.5\%$ ), 140 A, 1.65 ms, 5 Hz. We use a chopper-type Marx power supply that combines a Marx circuit and a step-down chopper circuit to provide long pulse power. Each Marx cell can provide an output voltage of -1.6 kV., 4 Marx cells as a unit can provides -6.4 kV output voltage, and 20 units as a system can provide -128 kV output voltage. However, the use of a chopper will certainly generate a peak voltage, which may cause breakdowns of electronic components. This report studies the effect of the above factors on the output of the power supply by adjusting the capacitance and resistance of the power supply circuit, adjusting the duty cycle, and adjusting the temperature.

#### 1. Introduction

In the International Linear Collider (ILC), a multi-beam klystron of 10 MW will be used as a microwave source. As shown in Table 1 for the power supply of the multi-beam klystron, a long pulse power supply is required with high precision as compared with a general high voltage pulse power supply. At the same time, we need to develop a more reliable, efficient, small, low-cost power supply. If we try to realize this specification with a MARX power supply using only capacitors or pulse transformers, it is inevitable to increase the size of the power supply. Therefore, a chopper type MARX power supply which combines a MARX circuit with a step-down chopper circuit has been proposed. The charging voltage of each cell is 2 kV and the output voltage is 1.6 kV. Each four cells are superimposed into one unit, and the output voltage of each unit is 6.4 kV. With a superposition of 80 cells we can get an output voltage of 120 kV.

Table 1: Specification of Pulsed Power Supply [1]

Output Voltage	-120 kV
Output Pulse Flat-top	$< \pm 0.5\%$
Output Current	140 A
Pulse Width (flat-top)	1.65 ms
Pulse Repetition Frequency	5 Hz
Rise time and Fall time	$< 0.1$ ms
Energy deposited into klystron during a gun spark	$< 20$ J

#### 2. Chopper type MARX power supply

Figure 1 shows the circuit of a unit chopper type MARX power supply. When  $SW_C$  is turned on, the capacitance of each cell is charged in parallel. When  $SW_D$  is turned on, the PWM control determines the waveform of the output voltage based on the capacitor  $C_M$  voltage and duty ratio in each MARX cell. By superimposing the voltages while shifting the phase of each stage of MARX, it is possible to reduce ripples generated in the step-down chopper.

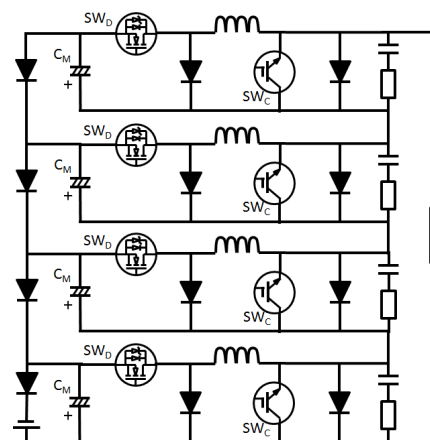

Figure 1: Simplified circuit schematic of chopper-type Marx modulator.

<sup>#</sup> s175082@stn.nagaokaut.ac.jp



Figure 2: Actual photo of a unit chopper type MARX power supply.

### 3. Power supply evaluation test

For phase control, under ideal conditions, the phase shifts by  $1/80$  of the PWM period of each cell, and the output voltage has the lowest ripple rate. In order to prove the influence of phase shift on the ripple rate, simulation experiments were performed on multiple cells and verified. First, an experiment was conducted in the case where no phase shift was performed on four cells, and the influence of the phase shift on the ripple rate of a plurality of cells was verified. The comparison of the experimental results is as follows. First, four MARX plates were used as experimental objects. When the charging voltage is 1000 V, the duty cycle is 80%~80%, the resistance is  $44 \Omega$ , and the phase shifts by  $1/4$  of the PWM period of each cell, the output voltage is shown in Fig. 3. Ripple rate is 5.56%. Then, 8 MARX plates were used as experimental objects. When the charging voltage is 1000 V, the duty ratio is 80%~80%, the resistance is  $88 \Omega$ , and the phase shifts by  $1/8$  of the PWM period of each cell, the output voltage is a Fig. 4 is shown. The ripple rate is 2.43%.

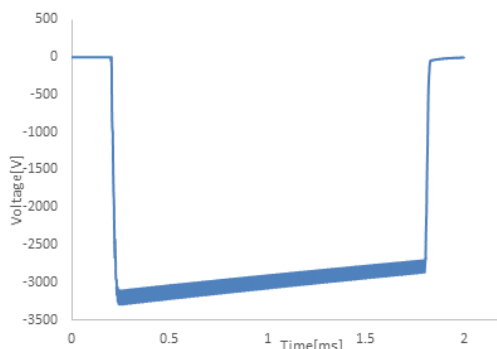

Figure 3: Output voltage at 1/4 shift.

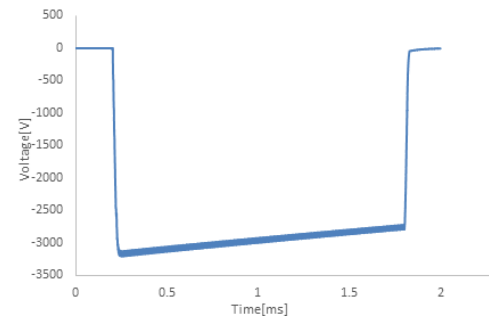

Figure 4: Output voltage at  $1/8$  shift.

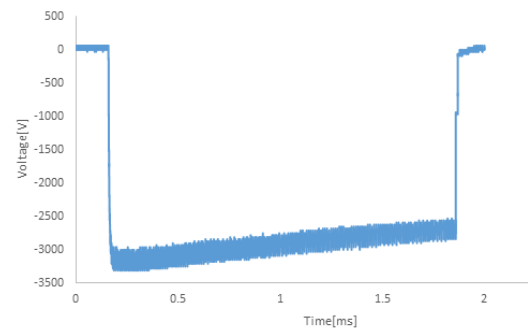

Figure 5: Actual output voltage at  $1/4$  shift.

From the above data, we can conclude that increasing the number of MARX substrates and controlling the phase can effectively reduce the ripple rate under the conditions of constant input voltage, duty cycle and the like. However, there are other irresistible factors in the actual operation that increase the ripple rate, and the actual data is usually larger than the simulation data. As shown in Fig. 5, the actual output voltages of the four MARX substrates at a duty ratio of 80%~80% and an input voltage of 1000 V, the phase shifts by  $1/4$  of the PWM period of each cell. The ripple rate is 9.11%.

### 4. Summary

The chopper type MARX power supply was tested as a power supply for a 10 MW multi-beam klystron for ILC. The phase shift between the cells is adjusted to confirm the effect of the phase factor on the output voltage. In future experiments, we will adjust the duty cycle through PWM to make the output voltage more stable.

### References

- [1] ILC Technical Design Report Volume 3 – Accelerator, 2013; <http://www.linearcollider.org/ILC/Publications/Technical-Design-Report>
- [2] Yuki Kozasa *et al.*, “Solid-state Marx generator for international linear collider”, 2014 IEEE International Power Modulator and High Voltage Conference (IPMHVC), Santa Fe, NM, USA, 1-5 June 2014, pp.1-6.