

J-PARC MR HORIZONTAL EXCITER TEST FOR TRANSVERSAL NOISE APPLICATION

Alexander Schnase^{#,A)}, Kenichirou Satou^{B)}, Masahito Tomizawa^{B)}, Takeshi Toyama^{B)},
 Masahiko Uota^{B)}, Masahito Yoshii^{B)}

A) JAEA J-PARC Center, B) KEK J-PARC Center

Abstract

To improve the duty factor of the proton beam, extracted by slow extraction to the Hadron hall, we applied transversal noise using the existing horizontal exciter in J-PARC Main-Ring (MR). For noise center frequencies of 5 and 7.5 MHz, operation was possible; however in a band above 6 MHz, we noticed that the pressure in the vacuum chamber increased near the exciter structure. Higher noise center frequencies seem to improve the duty factor seen by the Hadron experiment, therefore we tried frequencies near 30, 25, and 20 MHz. Vacuum pressure rise detected near the exciter led to the decision to limit the operation time to prevent beam loss and damage to the exciter structure itself. Afterwards, to understand the mechanism of the pressure rise, we mapped safe and unsafe operation points as function of frequency and amplifier output power. We found a safe operation area, e.g. no pressure rise, for the extraction beam time planned for the April 2011 run, however due to the big Tohoku earthquake the beam time was postponed. Improved noise signals, where the amplitude distribution is independent of noise bandwidth have been created and we drove the exciter with them to confirm the feasibility. We confirmed that a solenoid around the exciter improves the multi-pactor issues. With a solenoid current of 2 A, the frequency range from 1 to 35 MHz is free from vacuum problems for the whole output power range of the used 1 kW RF transistor-amplifiers. Further ideas and recommendations for improvement include rounding of the exciter electrode edges or coating the electrodes, when 2 shorter upgraded transversal exciters, better matched to higher noise center frequencies of at least 50 MHz are derived from the existing structure and placed at the appropriate positions, related to the MR lattice.

INTRODUCTION

In the slow extraction operating mode, after acceleration to 30 GeV, the proton beam is extracted from the J-PARC Main-Ring (MR) to the Hadron experimental area by a 3rd order resonance extraction method [1]. The duty factor of the extracted beam can be improved by applying narrowband well-defined pseudo-noise [2]. How to generate such signals is described in more detail in [3]. The set-up to apply transversal noise to the beam is shown in Fig. 1. The MR horizontal exciter, which is normally used to excite the beam transversally for tune measurement can also be used for slow extraction studies. In such case the low-level signal source is a noise synthesizer. For noise center frequencies near 5 and

7.5 MHz, operation for extraction beam studies was possible in October 2010.

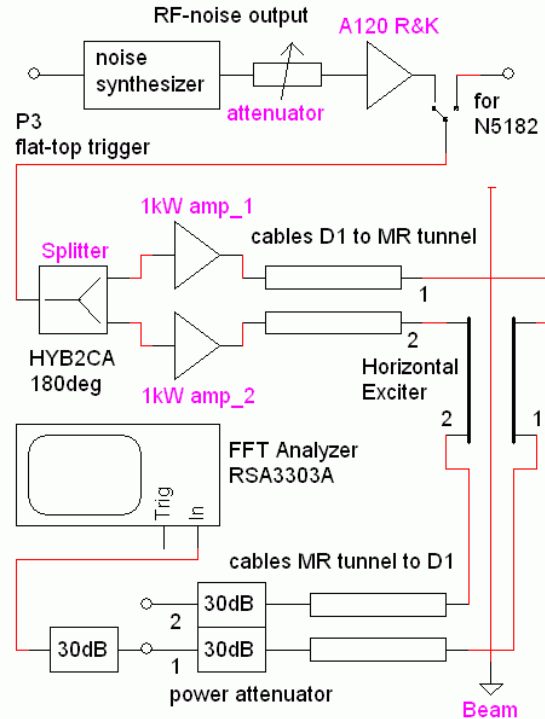

Figure 1: Applying transversal noise to the beam by horizontal exciter.

Fig. 2a shows the time interval spectrum taken by the Hadron E19 group in RUN 35 [4] in case of transversal noise OFF. The situation with transversal noise ON is shown in Fig. 2b. As it was understood, the E19 group is not so happy with the peaks at multiples of 200 ns.

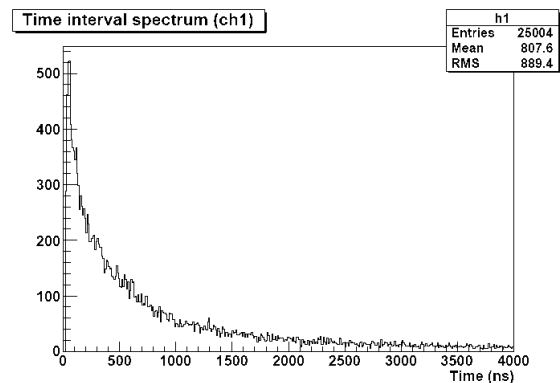

Figure 2a: time interval spectra taken in RUN 35. Transversal noise is OFF.

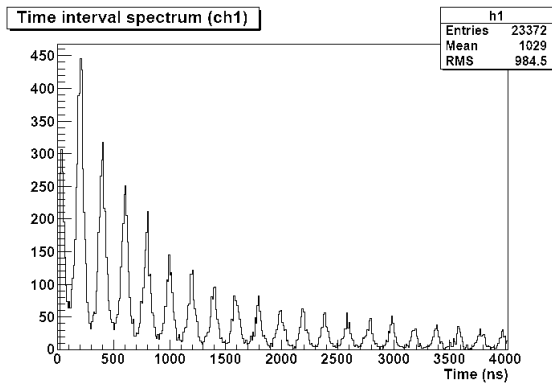

Figure 2b: time interval spectra taken in RUN 35. Transversal noise is ON with 1 kHz width near 5 MHz.

An example of the applied noise signals is given in Fig. 3. The noise left edge was set at 5.033377 MHz and the width at 1 kHz. Due to distortions in the 1 kW transistor amplifiers two 1 kHz wide lower sidebands appear each to the left and right of the original. For frequencies a little bit higher than 6 MHz, we noticed that the pressure in the beam pipe near the exciter, measured at the vacuum gauge IG_015 was going up. For frequencies higher than 7 MHz this phenomenon did not occur, so we were able to apply transversal noise to the beam around $39.332328 \cdot f_{rev} = 7.51905$ MHz, too. Still the Hadron experiment found a time-interval structure like in Fig. 2b, but with multiples spaced approximately 134 ns apart.

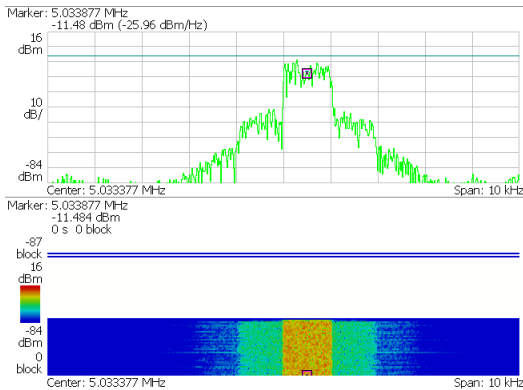

Figure 3: An example of a transversal noise signal measured in the exciter return path.

Thus we wanted to try to operate the exciter at higher noise center frequencies. The original DSP and DDS based noise generator was limited by the analog reconstruction low-pass filter behind the DAC to approximately 10 MHz. Operation until 20 MHz is possible, however the unwanted harmonic content goes up. Therefore we experimented with a borrowed Vector Signal Generator Agilent N5182A. This device can operate up to 6 GHz. Internally it contains a mixer that can be modulated by a complex IQ-signal. I and Q mean “In-phase” and “Quadrature phase”. Up to 64 Mega I-Q modulation points at up to 125 Msamples/s can be used for modulation sequences, and the 4 GB internal storage equal to 800 Million points allows preparing and storing

several noise modulation files in advance. Remote operation via WEB-browser interface is helpful to access the device from the accelerator control room without the need for programming the communication. For 20 noise bandwidths from 100 Hz via 1 kHz up to 5 kHz the modulation sequences were prepared with 2^{20} IQ vector points each for 320 kHz modulation sample rate. The original 1 kW Thamway amplifiers for the MR exciter were limited in their upper frequency range to less than 8 MHz, therefore we temporarily installed 2 older ENI A 1000 amplifiers, also 1 kW types, which can operate up to 35 MHz in the D1 power supply room. The available gain and power is frequency dependent, as shown in Fig. 4 for the ENI amplifier with serial number #395 as example.

#395 RF group: Output power as function of frequency with fixed 0dBm input

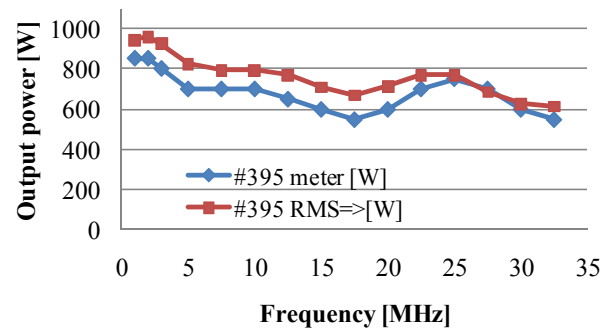

Figure 4: Amplifier output power for constant 0 dBm input level measured by internal power meter (blue) and by oscilloscope (red) after 60 dB power attenuator.

In RUN 36, after a noise study with 3 noise bands using the existing Thamway amplifiers had finished, we changed to 2 ENI amplifiers. Checking the signal level started with a sine-wave at 30 MHz. As seen in Fig. 5, the IG_15 pressure value increased from $2 \cdot 10^{-7}$ to 10^{-2} Pa, so we stopped the RF source and the pressure went down. With noise near 25 MHz (24.914764 MHz) the pressure rise was still too high.

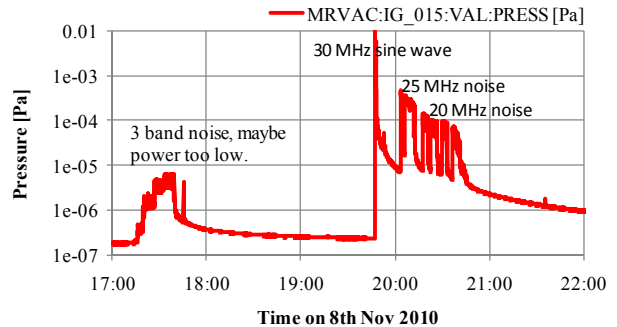

Figure 5: IG_015 pressure history (RUN 36) near exciter.

With narrow-band noise near 20 MHz, e.g. at 19.944418 MHz the vacuum pressure rise in the order of 10^{-4} Pa was acceptable so that the E19 group could take some data to find out, if the duty factor of the extracted

beam is improved. However it was decided that longer time user operation with the risk of vacuum problems at the horizontal exciter should be avoided. As it turned out [5], with transversal noise at approximately 20 MHz, the duty factor can be improved, compared to transversal RF off and also compared to using lower noise frequencies. The next slow extraction user run was planned for April 2011. In the time between we tried to find the cause of the vacuum problems.

MAPPING SAFE AND UNSAFE OPERATION POINTS

From the end of November 2010, we had a chance to test the behaviour of the MR horizontal exciter during accelerator maintenance periods. At this time, instead of the 1 kW amplifiers, a pair of R & K wideband amplifiers, installed for the bunch by bunch feedback [6], were connected to the horizontal exciter. The output power is limited to approximately 500 W each. The wideband characteristic enabled us to measure up to 100 MHz. As signal source we used a R&S network analyzer. One of the return signals from the exciter with proper 50 dB attenuation in the path was connected to the network analyzer input to measure the transfer function S_{21} . The idea was, if there is a vacuum problem, a discharge in the exciter can be detected as a S_{21} drop. For 60 s frequency sweeps from 0.15 MHz to 10 MHz at levels from -30 dBm to 0 dBm at the input of the 180 deg power splitter HYB2CA, connected to the pair of power amplifiers, we could not detect any case of pressure level rise.

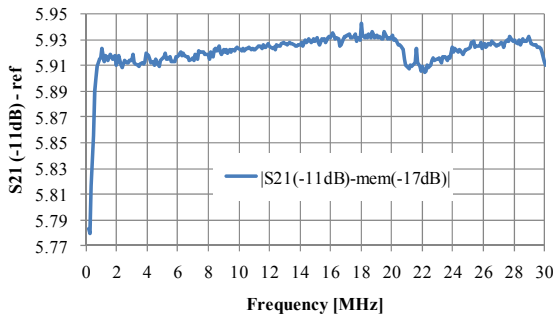

Figure 6: Frequency sweep from 0.15 to 30 MHz

Then we extended the frequency range to 30 MHz, and in 1 dB steps, we increased the signal level. With a reference at -17 dB attenuator setting, we noticed a pressure increase at attenuator setting -11 dB. Fig. 6 shows the S_{21} difference between the reference and the measurement at -11 dB. Between 0.15 MHz to 19 MHz, it seems to be a safe region, while the S_{21} drop between 20 and 24 MHz and the S_{21} drop for frequencies higher than 28 MHz indicate unsafe operating regions, where the pressure rise indicates possible discharges.

For a wider sweep from 0.15 to 100.15 MHz in 2 s, Fig. 7 shows how S_{21} drops in the multi-pactor region starting from approximately 30 MHz. At -12 dB setting where the vacuum meter reading was stable (in other words it did not go up when rf is applied), a reference is taken, and for each 1 dB step up, the S_{21} drop becomes bigger, while the pressure value rises.

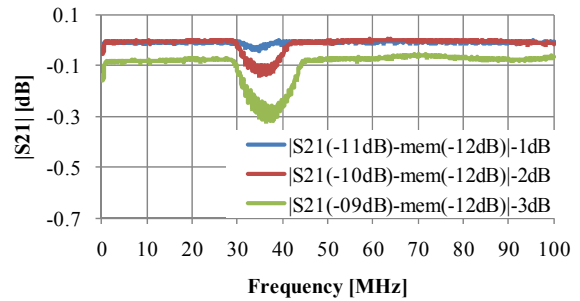

Figure 7: Frequency sweep from 0.15 to 100.15 MHz. From blue via red to green the level increased by 1 dB.

While this method allows detecting possible multi-pactor regions, there is the problem that once a discharge has started, it may take time that a discharge stops and the pressure reduces back to former lower values. Also we could not operate the network analyzer to sweep backwards in frequency for confirmation. Therefore we zoomed into the suspicious areas. An overview of the mapping as of December 2010 is given in Fig. 8. Light blue areas indicate points, where no pressure rise as function of frequency or signal source level was found. Yellow or orange points indicate that the pressure was rising significantly more (>10%) than usual fluctuations. Assuming a discharge happens, we call this an unsafe operating point.

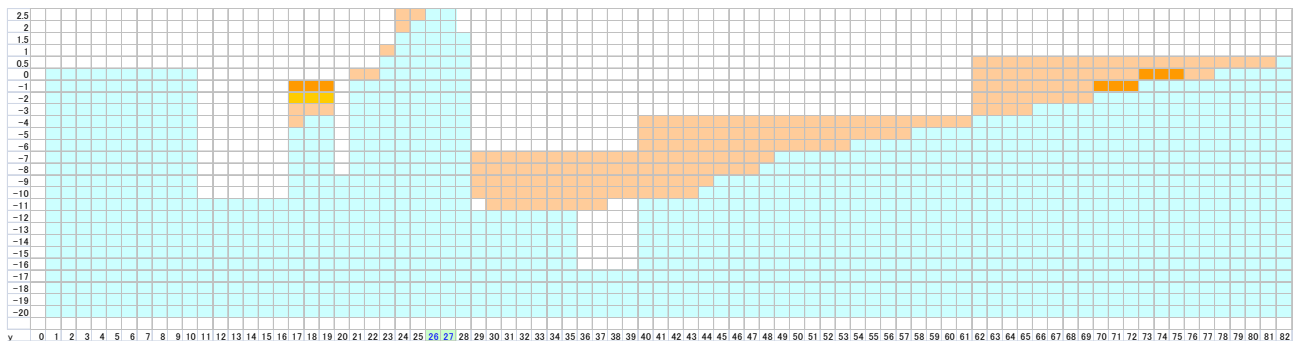

Figure 8: Mapping of safe and unsafe points. The signal source level is in 1 dB steps from -20 to 0 dBm and in 0.5 dB steps from 0 to +2.5 dBm on the left side. The horizontal frequency axis is from 1 to 82 MHz in 1 MHz steps.

Frequencies from 83 to 100 MHz are not shown, as they are similar to the 82 MHz result. From Fig. 8, the frequency range from 26 to 27 MHz was a candidate for exciter operation in April 2011, however due to the big Tohoku earthquake the beam time was postponed.

EFFECT OF A SOLENOID INSTALLED AROUND THE MR-EXCITER

The information given in Fig. 8 is not complete to describe multi-pactor issues, because if there is an unsafe region with rising rf power, there should be another region at even higher power, which is safe again. In the time between we received the ordered Vector signal generator Agilent N5182A, and we re-connected the exciter to the set of 1 kW ENI amplifiers. We measured the frequency range between 1 MHz and 35 MHz in 1 MHz steps again, while the signal generator level was varied from -30 dBm up to the point, where either the pressure, indicated by vacuum gauge IG_15 starts to rise, or one of the amplifier power meters indicated over 1 kW. Once a point was found, where the pressure went up, we returned to the last safe point and decreased the power step size so that we could pin-point the transition from safe to unsafe operation with 0.1 dB. In such case we also tried to jump to maximum available power and stepwise decreased the level, thereby being able to locate the power level, where multi-pactor disappears with increased rf level. These results are summarized in Fig. 9. The measurement uses the return cable from electrode 1, connected to power attenuator 1 in the D1 power supply room. Taking the frequency dependent attenuation of the cables into account, the actual electrode voltage is in the order of 10 to 20% higher. The lowest generator level of -30 dBm corresponds to around 5 Vp at attenuator 1 and is indicated in dark blue with the legend entry “1press. ok from”. At this voltage was no pressure rise. Light blue is the 2nd area, labelled “2press. ok to” and this means up to the given voltage the pressure reading kept stable. The transition region “3press. rise from” is quite sharp, a 0.1 dB step is equivalent to a 1.02% voltage change, so the next region shown in yellow is “4press. rise to”. For voltage levels in the yellow area 4 the pressure value was rising, so operation in area 4 is regarded as unsafe. Finally the 6th region in purple indicates the power level, where the pressure does not rise, so this is safe to operate.

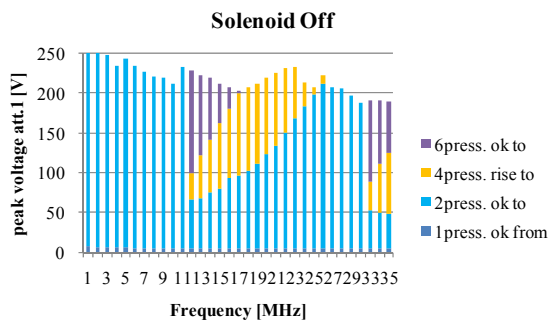

Figure 9: MR-exciter safe and unsafe operation area

There are differences between Fig. 8 and 9, which might be explained by [7]. Fig. 10 shows the solenoid structure installed around the horizontal exciter, which is designed to suppress the multi-pactor issues. There are 12 sets of coils, each with 100 turns and a DC resistance in the order of 0.6 Ω. The B-field strength for radii 65, 108, and 128 mm together with measured points for confirmation is shown in Fig. 11. The on-axis B-field is in the order of 5 mT for 5 A current.



Figure 10: Setup of solenoid around the MR exciter.

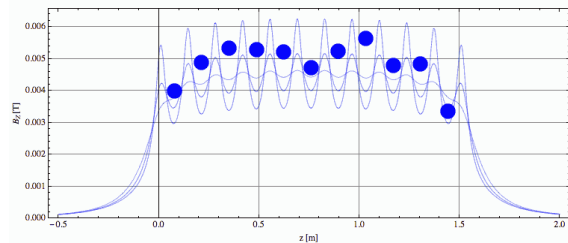

Figure 11: The B-field is approximately 5 mT for 5 A.

With 5.1 A solenoid current, 40.5 V appeared at the power supply terminals. Fig. 12 shows, the pressure rise completely disappears within the covered parameter range. We lowered the solenoid current in 1 A steps, measured again and confirmed that a solenoid current of 2 A is sufficient for the given rf parameter range.

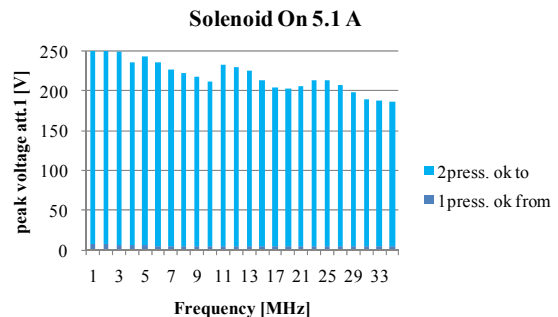

Figure 12: Pressure stable with solenoid current 5.1 A

Lowering the solenoid current even further, we noticed that to suppress the left yellow area from 12 to 26 MHz in Fig. 9, a solenoid current of 0.5 A is sufficient. However, for the right yellow area in Fig. 9, solenoid currents of 1.5 A at 33 MHz and 2 A at 35 MHz were required.

Single electrode exciter test (solenoid off)

The different required solenoid currents in the 2 yellow areas in Fig. 9 can be related to different multi-pactor modes at the exciter electrodes. To confirm this, we re-measured the parameter range in Fig. 9 with only one of the RF amplifiers active. For the frequency range up to 31 MHz, covering the left yellow area in Fig. 9, no pressure rise with solenoid off was detected. This leads to the conclusion that the pressure rise in the left yellow area is related to discharges between the 2 exciter electrodes. As shown in Fig. 13, when only amplifier 1 was active, the pressure rise occurs for voltages above 50 V, same as in Fig. 9. Therefore in this area the discharge is probably between a single electrode and ground. When only amplifier 2 was active (Fig. 14), there is no pressure rise at 33 MHz, but the values for 34 and 35 MHz are comparable to Fig. 13. It should be noted that for Fig. 14 the peak voltage was calculated from the amplifier power meter and scaled to reflect the value at power attenuator 2. For operating a single exciter electrode the discharge disappears at 35 MHz, when the voltage is above 100 V, whereas in Fig. 9 the discharge disappears above 125 V (so 250 V between electrodes). This indicates that there is probably a transition area from single electrode discharge to ground to the discharge mode between the electrodes.

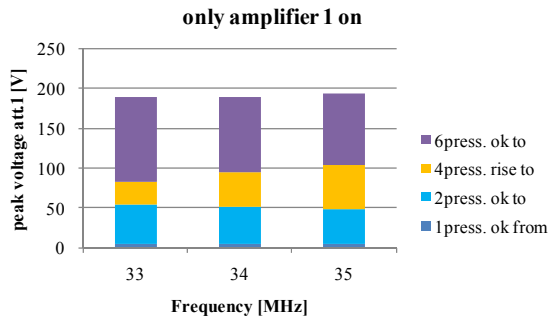

Figure 13: Only amplifier for exciter electrode 1 active.

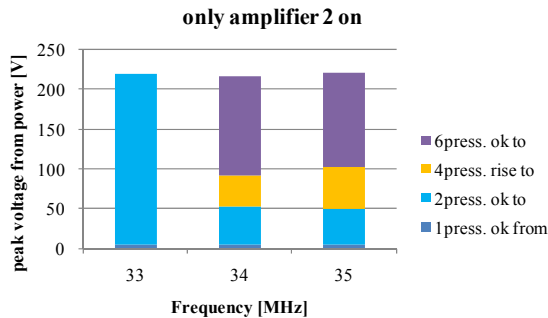

Figure 14: Only amplifier for exciter electrode 2 active.

Confirmation checks

The stability and reproducibility of the measurement is checked by comparing measurements on different days. Fig. 15 compares the gain of the combination of amplifier 1 and cables at small generator level of -30 dBm. The maximum variation from day to day is less than 0.1 dB, which is consistent with the 0.1 dB step size.

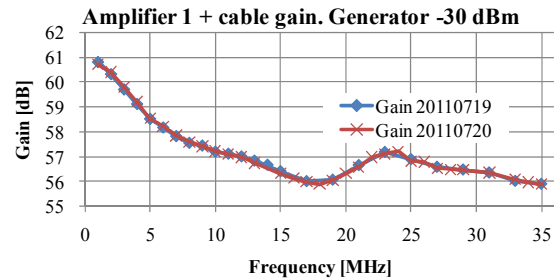

Figure 15: Combined gain of amplifier 1 and cables.

The narrow band low-level noise signals were prepared so that the peak power is 3 dB higher than average power, and average power is bandwidth independent within 0.01 dB. At 29 MHz carrier frequency, where safe operation is possible without solenoid, we checked at 0 and +4 dBm signal generator level that the average power displayed by both amplifier power meters did almost not change (3% near 600 W), when the signal was changed from sine-wave to 5 kHz narrow width noise. So the exciter can be operated with the noise signals prepared to improve slow extraction.

SUMMARY AND OUTLOOK

We were able to map the safe and unsafe operating points of the MR exciter as function of frequency and power level. With a solenoid current of 2 A, there is no pressure rise in frequency range from 1 to 35 MHz for the whole output power range of the used 1 kW RF transistor-amplifiers. In the future we try more wideband 1 kW amplifiers to extend the covered frequency range. Also we try to get a shorter exciter, better suited for higher frequencies in the order of 50 MHz or more. Then we might also have a chance to improve the exciter electrodes by rounding the edges or surface coating.

REFERENCES

- [1] M. Tomizawa, et. al, "Status and Upgrade Plan of Slow Extraction from the J-PARC Main Ring", IPAC10, Kyoto, THPEB014, p. 3192-3194
- [2] A. Schnase et al., "Application of Digital Narrow band noise to J-PARC Main Ring", IPAC10, Kyoto, TUPEA051, p. 1446-1448
- [3] A. Schnase, "Narrowband Noise signals with minimized amplitude variation", LLRF 09 workshop, Tsukuba, 20th October 2009, TP20
- [4] M. Naruki, "transverse RF for spill structure", J-PARC internal presentation 2010 Oct. 16
- [5] T. Takahashi, E19 group, "Transverse-RF Study", J-PARC internal presentation 2010 Nov. 8th
- [6] M. Tobiya et. al., "Bunch by Bunch Feedback Systems for J-PARC MR", IPAC10, Kyoto, WEPEB036, p. 2767-2769
- [7] M. Uota et. al. "Vacuum Surface Scrubbing by Proton Beam in J-PARC Main Ring", IPAC10, Kyoto, THPEA081, p. 3858-3860