

## PROGRESS OF THE ACCELERATOR IN BROADER APPROACH IFMIF/EVEDA PROJECT

K. Shinto\*, C. Vermare, T. Harami, M. Sugimoto, P. Garin, IFMIF/EVEDA Project Team,  
Rokkasho, Aomori 039-3212, Japan  
S. Maebara, H. Sakaki, S. O'hira, Y. Okumura, JAEA, Rokkasho, Aomori 039-3212, Japan  
A. Mosnier, CEA, IRFU, F-91191, Gif-sur-Yvette, France  
A. Ibarra, CIEMAT, Avda. Complutense 22, 28040 Madrid, Spain  
A. Facco, INFN/LNL, Legnaro (PD), Italy

### Abstract

International Fusion Materials Irradiation Facility (IFMIF) is an accelerator driven neutron source for investigation of the fusion plasma facing materials. The accelerator consisting of two linacs provides continuous-wave (CW) positive deuteron ion ( $D^+$ ) beams with total intensity of 250 mA at the beam energy of 40 MeV. Engineering Validation and Engineering Design Activities (EVEDA) for the IFMIF is one of the three projects of Broader Approach (BA) Agreement in the field of fusion energy research and development between EURATOM and the Government of Japan. In the project starting from the middle of 2007, a prototype accelerator will be tested for the low energy part of the IFMIF accelerators. The prototype will provide the CW  $D^+$  beam with the intensity of 125 mA at the energy of 9 MeV.

### INTRODUCTION

In order to realize energy production using nuclear fusion reactions, a selection of plasma facing materials to overcome neutrons with the energies of 14 MeV produced by D-T nuclear reactions is one of the most important issues. ITER is designed to undertake the physical properties of thermonuclear plasmas and the key technologies. However, the amount of neutrons produced in ITER will be two orders smaller than that produced in the next stage of fusion demonstrator called DEMO. IFMIF (International Fusion Materials Irradiation Facility) should be in charge of an investigation of materials under a high flux of energetic neutrons in order to design the DEMO.

As a framework in support of the ITER project and for an early realization of fusion energy, the joint implementation of the Broader Approach (BA) activities in the field of fusion energy research and development have been agreed between the European atomic energy community (EURATOM) and the Government of Japan in February 2007. The BA activities comprise the following three projects;

- the project on the Engineering Validation and Engineering Design Activities for the IFMIF (IFMIF/EVEDA),
- the project on the International Fusion Energy Research Centre (IFERC), and
- the project on the Satellite Tokamak Programme.

In this paper, after a brief description of the IFMIF, the progress of the accelerator system in BA IFMIF/EVEDA project will be presented.

### IFMIF

The IFMIF is an accelerator driven neutron source consisting of two linacs each of which provides a continuous-wave (CW) positive deuteron ion ( $D^+$ ) beam with the intensity of 125 mA (total 250 mA by two linacs) at the beam energy of 40 MeV. The two  $D^+$  beams interact with a 25mm-thick Li jet flowing at a speed of nominally 15 m/s and produce an intense flux of neutrons with the energy spectrum which is able to simulate the irradiation effects encountered in DEMO. The concept has been established for two decades[1],[2].

The IFMIF is constituted by the following three systems;

- the accelerator system
- the lithium target system, and
- the materials irradiation test system.

During 6 years of the IFMIF/EVEDA project since the middle of 2007, design, construction, operation and maintenance of a prototype accelerator as an Engineering Validation Activity (EVA) and an accelerator Engineering Design Activity (EDA) for the IFMIF including the interfaces with the lithium target system and the materials irradiation test system will be performed[3].

### PROTOTYPE ACCELERATOR OF IFMIF/EVEDA

The prototype accelerator consists of a 100 keV injector equipped with an electron-cyclotron-resonance type ion source (ECR-IS) and a low energy beam transport line (LEBT), a radio-frequency quadrupole (RFQ) linac accelerating the beam up to 5 MeV, the matching section (MS), the first section of half-wave-resonator type superconducting drift tube linacs (HWR SC-DTL) accelerating the beam up to 9 MeV, a high energy beam transport line (HEBT), a beam diagnostic system, a beam dump to endure the high energy beam power up to 1.2 MW in CW operation, RF high power sources and subsystems[4]. A schematic drawing of IFMIF/EVEDA prototype accelerator is shown in Fig. 1 and the main specifications are listed in Table 1. Most of the accelerator components will be provided by European institutions (CEA-Saclay, CIEMAT, INFN/LNL etc.),

\*shinto.katsuhiko@jaea.go.jp

while the RF couplers for the RFQ linac, the supervision of the accelerator control system and the accelerator prototype building constructed at Rokkasho BA site for the beam tests will be provided by JAEA.

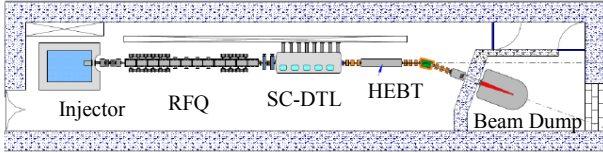

Fig. 1: A scheme of the prototype accelerator.

Table 1: Main specifications of the prototype accelerator.

Requirement	Specification
Particle type	D <sup>+</sup> (H <sub>2</sub> <sup>+</sup> for test to avoid activation)
Beam energy	9 MeV
Beam current	125 mA
RF frequency	175 MHz (both RFQ linac and DTL)
Duty factor	CW ( pulsed tune-up and start-up)

The ECR-IS with a four electrode extraction system is based on the development for SILHI source at CEA-Saclay. To obtain the D<sup>+</sup> beam intensity of 140 mA, the extracted energy of 100 keV and total current of 175 mA (with D<sub>2</sub><sup>+</sup> and D<sub>3</sub><sup>+</sup> beam of 35 mA) are required. The LEBT consists of a dual solenoid transport system equipped with the beam diagnostics.

A four-vane-structure RFQ linac will be provided for the IFMIF because of the ability in CW operation and lower power consumption for a given field. It will make the d.c. D<sup>+</sup> beam from the injector bunch and accelerate from 100 keV up to 5 MeV. The RFQ linac is finally designed with three functions as a shaper, a gentle buncher, and an accelerator in 9.8 meters long. The total RF input power is required about 1.6 MW and will be delivered by eight 220 kW RF power sources.

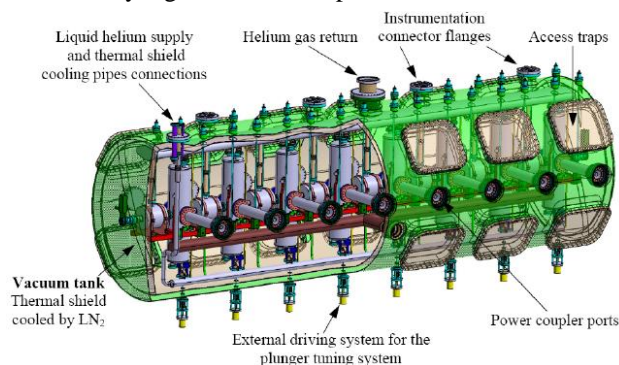

Fig.2: An overview of a possible cryomodule design of the HWR SC-DTL.

The DTL following the RFQ linac will make the bunched D<sup>+</sup> beam accelerate up to 9 MeV and 40 MeV in cases of IFMIF/EVEDA prototype accelerator and IFMIF accelerators, respectively. Because of a lot of technical and financial advantages (RF power reduction, high

flexibility and reliability, mature technology and better suited to existing teams and industries, less sensitive to all machining and assembly errors), a superconducting option is selected and the HWR SC-DTL has been being under investigation to fit the IFMIF accelerators. An overview of a possible cryomodule design is shown in Fig. 2 and main parameters of the SC-DTL are listed in Table 2.

Table 2: Main parameters of the HWR SC-DTL.

Cryomodules	1	2	3 & 4
	(for IFMIF)		
Cavity $\beta$	0.094	0.094	0.166
Cavity length (mm)	180	180	280
Beam aperture (mm)	40	40	48
Nb cavities/period	1	2	3
Nb cavities/cryostat	1x8	2x5	3x4
Nb solenoids	8	5	4
Cryostat length (m)	4.64	4.30	6.03
Output energy (MeV)	9	14.5	26/40

Following the change from a normal conducting DTL to SC-DTL, the RF power system can be made to be simpler, more reliable and conventional power units using tetrodes than the original design of RF power system using three 1MW diacodes. RF power requirements for the prototype accelerator are shown in Fig. 3. The 220 kW units for RFQ linac can standardize those for the whole accelerator. A schematic drawing of a removable RF power module is shown in Fig. 4.

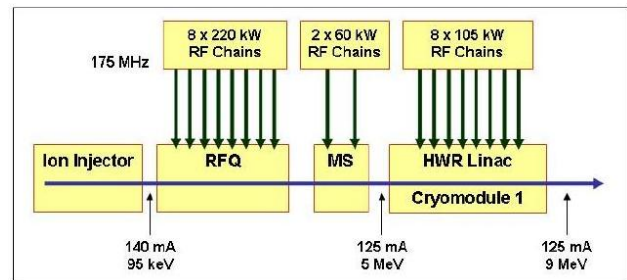

Fig. 3: A scheme of RF power requirements for the prototype accelerator.

The HEBT of the prototype accelerator consists of the first triplet focusing system for the beam to fly through a 3-meter diagnostic plate (D-plate), a doublet focusing system to compensate the variations of the first triplet system in case of emittance measurement by means of a quadrupole scanning method, a 20-degree bending magnet to avoid neutron back-streaming from the beam dump and possibly to measure the energy spread, and the second triplet focusing system to expand the beam at the beam dump area. Main diagnostic instruments and methods are listed in Table 3. Other instruments may be installed onto the D-plate in future for further tests.

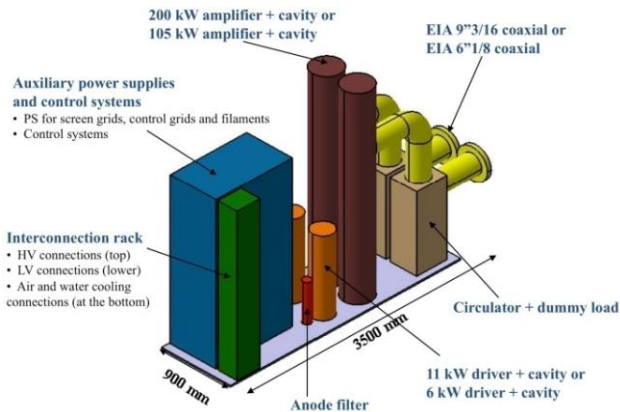

Fig. 4: A scheme of removable RF power module.

Table 3: Main diagnostic instruments and methods.

Measurement	Instrument/Method
DC current	DC current transformer (DCCT)
AC current	AC current transformer (ACCT)
Position	Short strip-line type BPM (SBPM)
Transverse profile	Gas fluorescence (FPM) Gas ionization (BTPM)
Transverse halo	Segmented ring (SHM)
Transverse emittance	Quadrupole scanning
Mean energy	SBPM
Energy spread	Magnetic dipole (MD)
Longitudinal profile	SBPM spectra
Longitudinal emittance	Buncher scanning
Beam loss	(under investigation)

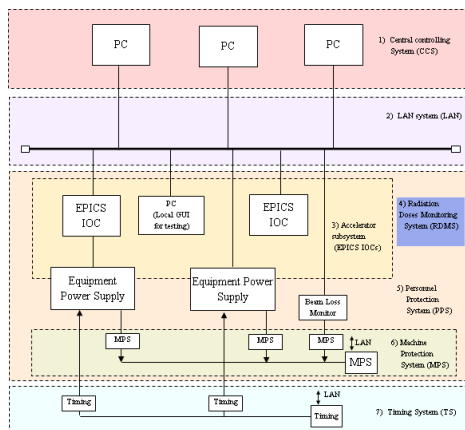

Fig. 5: An overview of the control system architecture for the prototype accelerator.

In case of the prototype accelerator, a beam dump is required to stop the  $D^+$  beam with maximum power of 1.125 MW. A selection of the beam facing materials has to take into account the neutron production and the

activation level as well as the thermal stresses. The design of the beam dump is under investigation.

In order to keep safety with satisfying the laws and regulations in Japan and to operate the prototype accelerator properly, the central control system comprises of seven control subsystems;

- Central Control System (CCS),
- Local Area Network system (LAN),
- Control for the prototype accelerator subsystems (EPICS IOCs),
- Radiation Dose Monitor System (RDMS),
- Personnel Protection System for non-exposed to radiation doses (PPS),
- Machine Protection System for the prototype accelerator (MPS), and
- Timing System for the prototype accelerator (TS).

An overview of the control system architecture including the subsystems for the prototype accelerator is shown in Fig. 5.

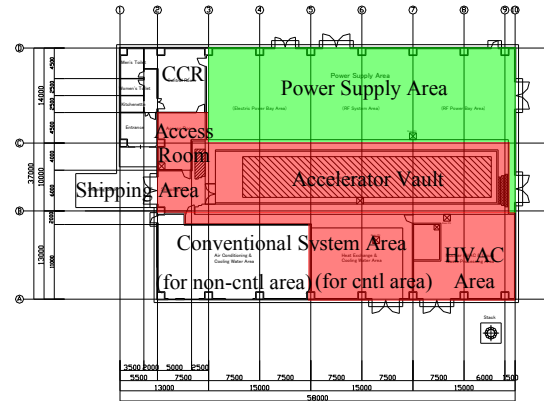

Fig. 6: Layout of the IFMIF/EVEDA accelerator building.

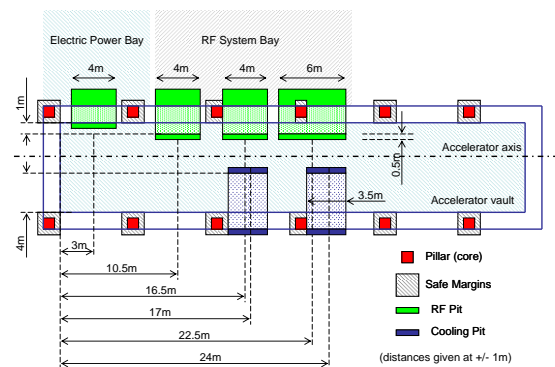

Fig. 7: Position of the underground pits between the accelerator vault and the neighbour rooms. The distances are indicated within a precision of  $\pm 1$  m.

The IFMIF/EVEDA accelerator building in Rokkasho BA site is shown in Fig. 6. The building consists of an accelerator vault, a nuclear heating ventilation and air conditioning (HVAC) area, a heat exchange and cooling water area for both controlled and non-controlled areas, an access room, a power supply area comprising an electric power bay space, an RF system area and an RF power bay

room, a central control room, a shipping bay area and a shipping deck. The accelerator vault is surrounded by concrete walls of 1.5 meters thick. For RF coaxial lines and waveguides and water cooling pipes, some underground pits are prepared between the accelerator vault and the neighbour rooms as shown in Fig. 7.

### **CONCLUSIONS AND PERSPECTIVES**

The components of the prototype accelerator will be provided by CEA-Saclay, CIEMAT, INFN/LNL and JAEA. Each of them will be designed, manufactured and tested in each institution and shipped to Rokkasho BA site for integration as a prototype accelerator. The integration test of the prototype accelerator and the beam commissioning at Rokkasho are planned to start in

October 2011 and progress as they come in. On the other hand, the EDA for the IFMIF should be performed in parallel to the EVA, immediately.

### **REFERENCES**

- [1] M. Martone *ed.*, IFMIF – International Fusion Materials Irradiation Facility Conceptual Design Activity – Final Report, ENEA, Frascati, Report, RT/ERG/FUS/96/11, December, 1999.
- [2] IFMIF International Team, “IFMIF Comprehensive Design Report (CDR)”, January 2004.
- [3] P. Garin, Proc. of EPAC08 (in press).
- [4] A. Mosnier *et al.*, Proc. of EPAC08 and its references (in press).